

SEE LANDSCAPE DRAWINGS FOR PLANTING MATERIALS

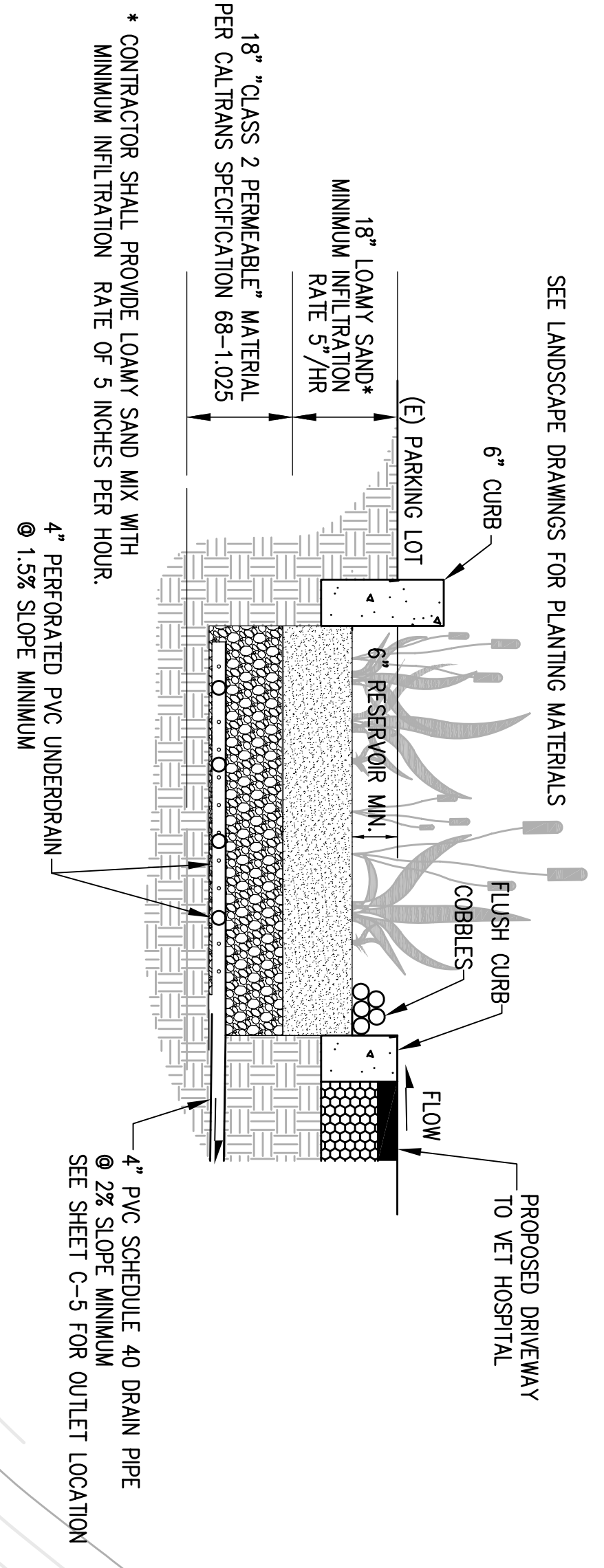

AREA	IMPERV. AREAS	IMPERV. AREA (SF)
1	ROOF AC PAVE.	31,299
2	AC PAVE.	5,778

BIO-RETENTION AREA (INFILTRATION PLANTER)
NOT TO SCALE

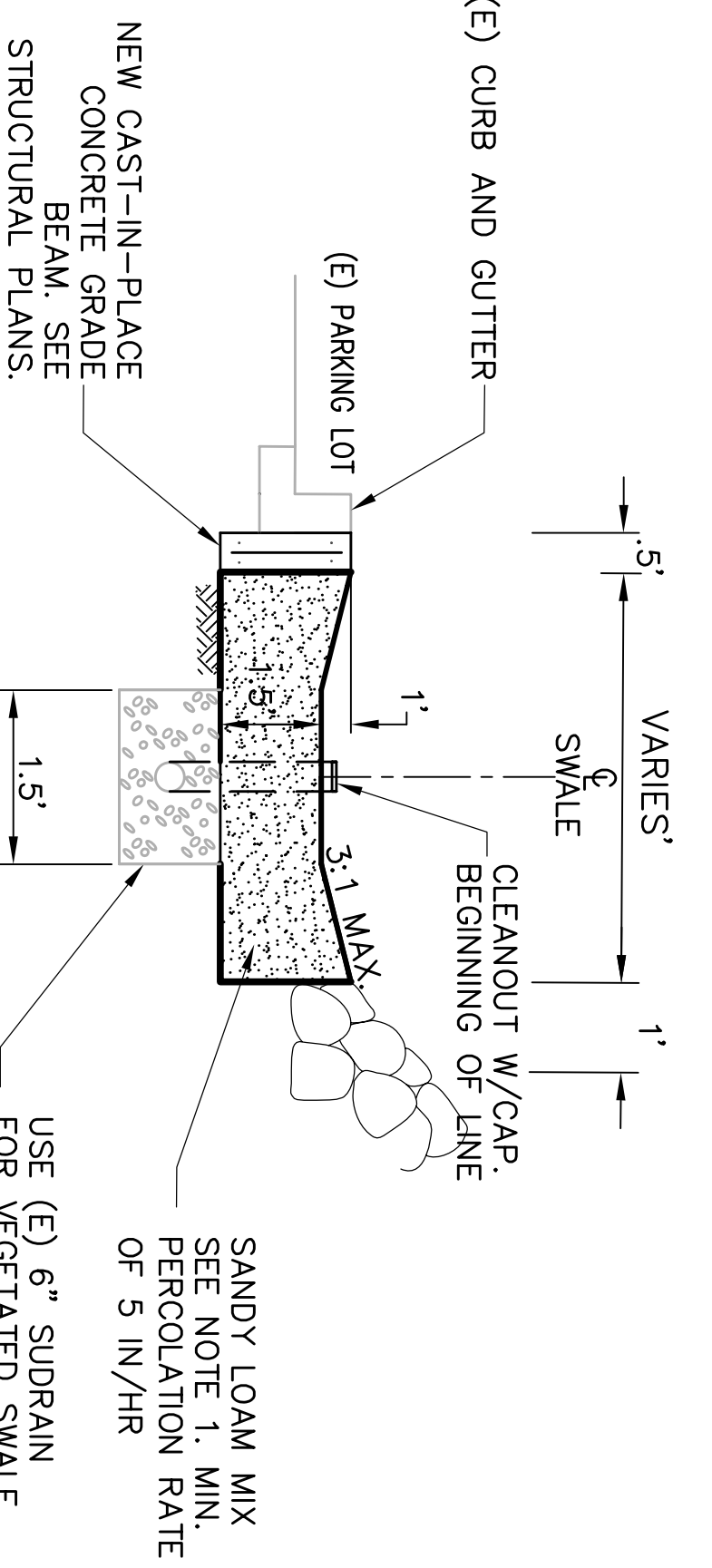
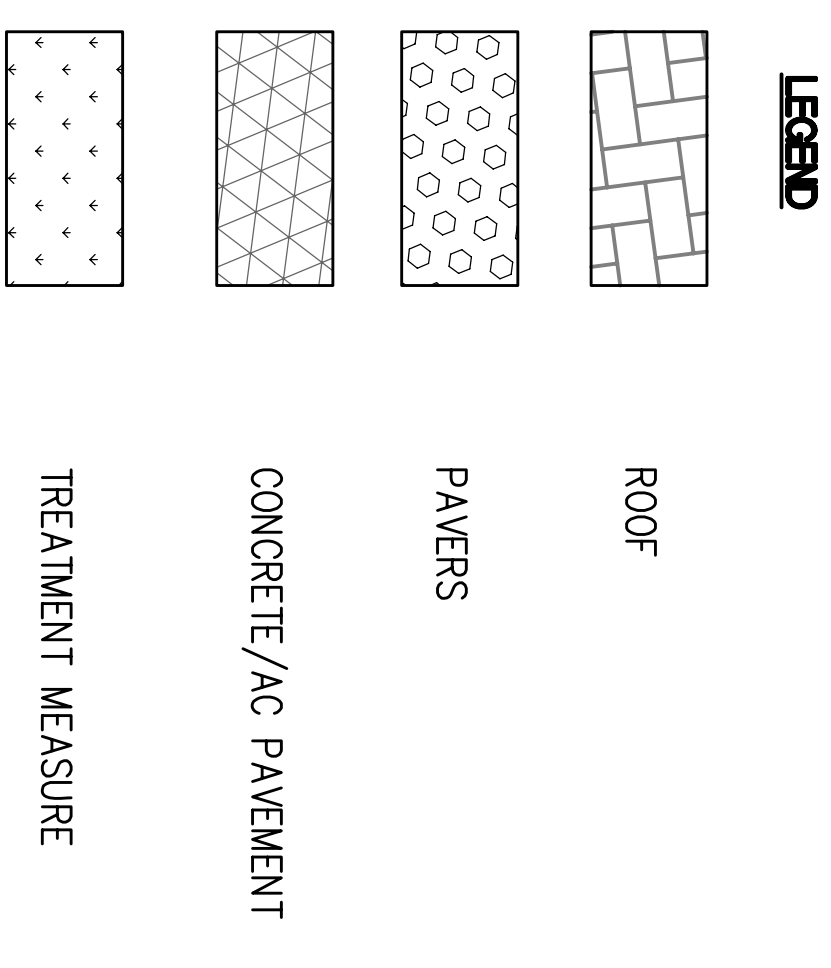

VEGETATED SWALE SECTION
NOT TO SCALE

- NOTES:
1. SANDY LOAM MIX SHALL BE 50% CONSTRUCTION SAND, 20%-30% TOPSOIL WITH 5% MAX. CLAY CONTENT, AND 20%-30% ORGANIC LEAF COMPOST.

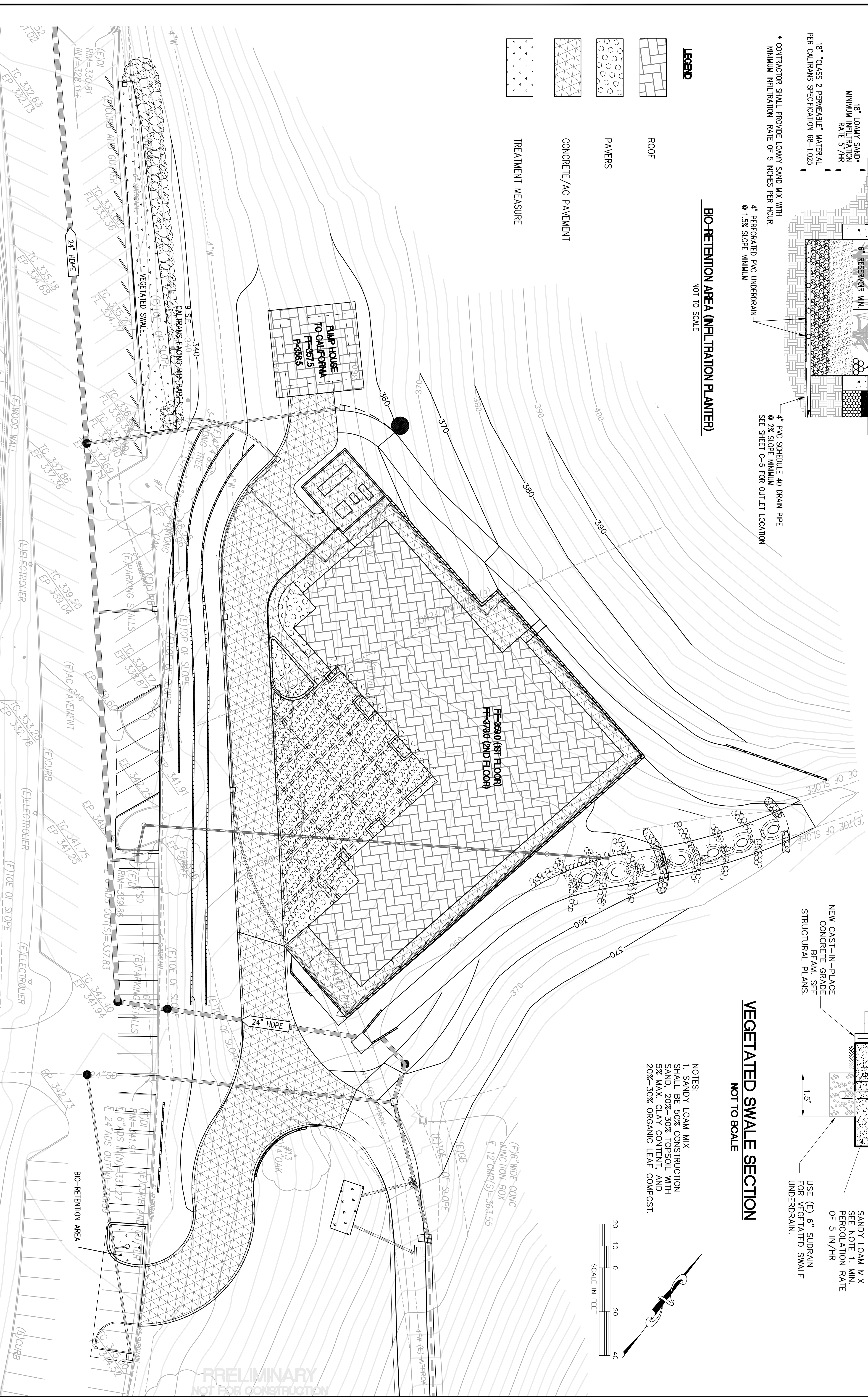
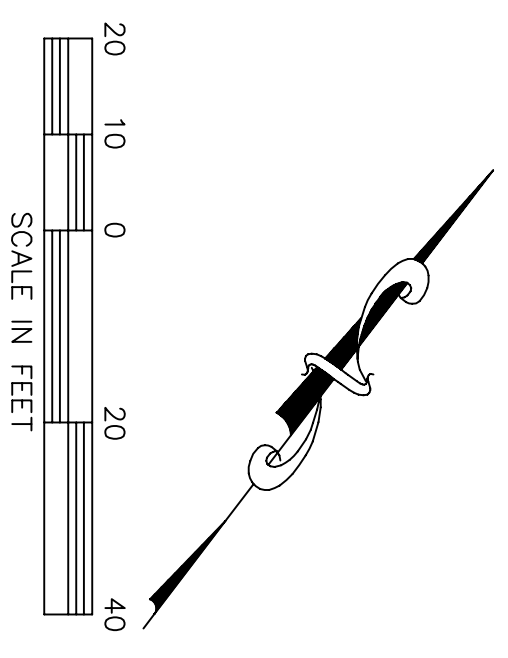

**PRELIMINARY POST-CONSTRUCTION
STORMWATER MANAGEMENT PLAN
THE CALIFORNIA EXHIBIT - CUP CM09085 - OAKLAND ZOO**

OAKLAND ALAMEDA COUNTY CALIFORNIA

No.	BY	DATE	REVISIONS

ALIQUOT
PLANNERS
CIVIL ENGINEERS
SURVEYORS

ALIQUOT ASSOCIATES, INC.
400 BOWLING GREEN WAY - 2ND
OAKLAND, CA 94610
(510) 661-5101
FAX: (510) 661-5171

JOB NO 208022
SCALE 1"=100'
DATE 6/15/2010
DESIGN
DRAWN MC
APPROVED

2 OF 2